

軸付砥石(軸径φ6.0mm) Grinding Points

軸の剛性が高く荒・中研削に適した、SGW φ6.0mm 軸付砥石シリーズです。
5砥粒6種類の砥石から用途に応じてお選びいただけます。

SGW φ6.0mm shank grindstone series with high shaft rigidity and suitable for rough and medium grinding.
With 5 types of abrasive grains, you can choose from 6 types of grindstones according to your application.

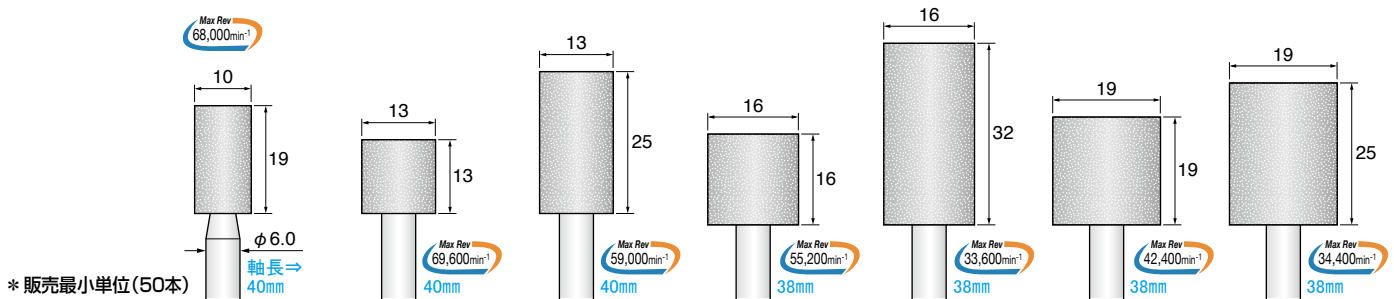

* 販売最小単位(50本)

WA(茶褐色)	SB1101 #60	SB1102 #60	SB1103 #60	SB1104 #60	SB1105 #60	SB1106 #60	SB1107 #60
WA(ホワイト)	SB1201 #60	SB1202 #46	SB1203 #46	SB1204 #46	SB1205 #46	SB1206 #46	SB1207 #46
A(グレー)	SB1301 #60	SB1302 #46	SB1303 #46	SB1304 #36	SB1305 #36	SB1306 #36	SB1307 #36
PA(ピンク)	SB1401 #60	SB1402 #60	SB1403 #60	SB1404 #60	SB1405 #60	SB1406 #60	SB1407 #60
GC(グリーン)	SB1501 #60	SB1502 #60	SB1503 #60	SB1504 #46	SB1505 #46	SB1506 #46	SB1507 #46
A(ブラック)	SB1601 #36	SB1602 #36	SB1603 #36	SB1604 #36	SB1605 #36	SB1606 #36	SB1607 #36

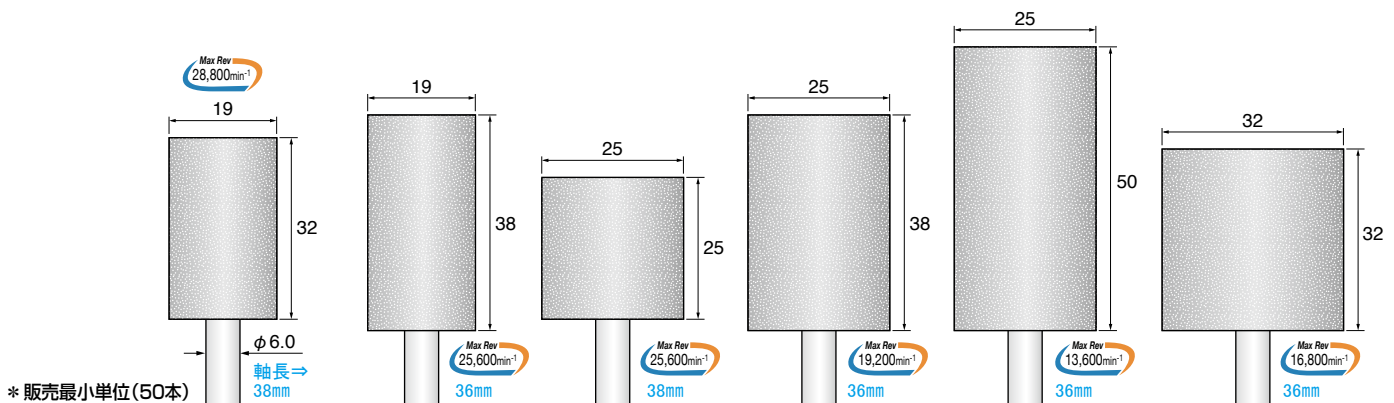

* 販売最小単位(50本)

WA(茶褐色)	SB1108 #60	SB1109 #60	SB1110 #60	SB1111 #60	SB1112 #60	SB1113 #60
WA(ホワイト)	SB1208 #46	SB1209 #46	SB1210 #46	SB1211 #46	SB1212 #46	SB1213 #46
A(グレー)	SB1308 #36	SB1309 #36	SB1310 #36	SB1311 #36	SB1312 #36	SB1313 #36
PA(ピンク)	SB1408 #60	SB1409 #60	SB1410 #60	SB1411 #60	SB1412 #60	SB1413 #60
GC(グリーン)	SB1508 #46	SB1509 #80	SB1510 #80	SB1511 #80	SB1512 #80	SB1513 #80
A(ブラック)	—	SB1609 #36	SB1610 #36	SB1611 #36	SB1612 #36	SB1613 #36

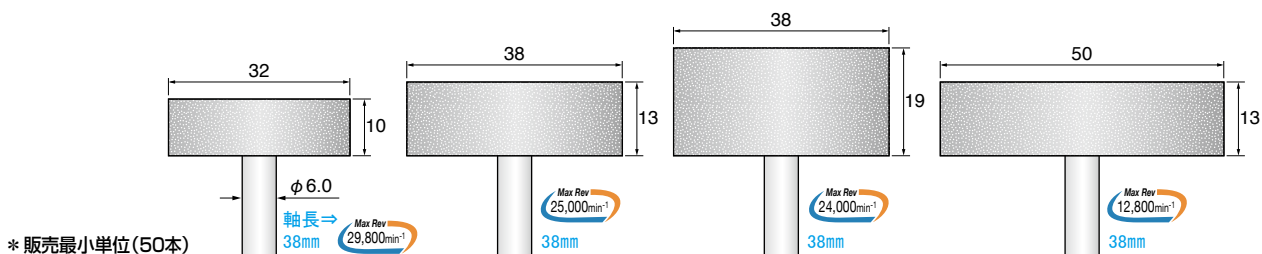

* 販売最小単位(50本)

WA(茶褐色)	SB1114 #60	SB1115 #60	SB1116 #60	SB1117 #60
WA(ホワイト)	SB1214 #46	SB1215 #46	SB1216 #46	SB1217 #46
A(グレー)	SB1314 #36	SB1315 #36	SB1316 #36	SB1317 #36
PA(ピンク)	SB1414 #60	SB1415 #60	SB1416 #60	SB1417 #60
GC(グリーン)	SB1514 #80	SB1515 #80	SB1516 #80	SB1517 #80
A(ブラック)	SB1614 #36	SB1615 #36	SB1616 #36	SB1617 #36

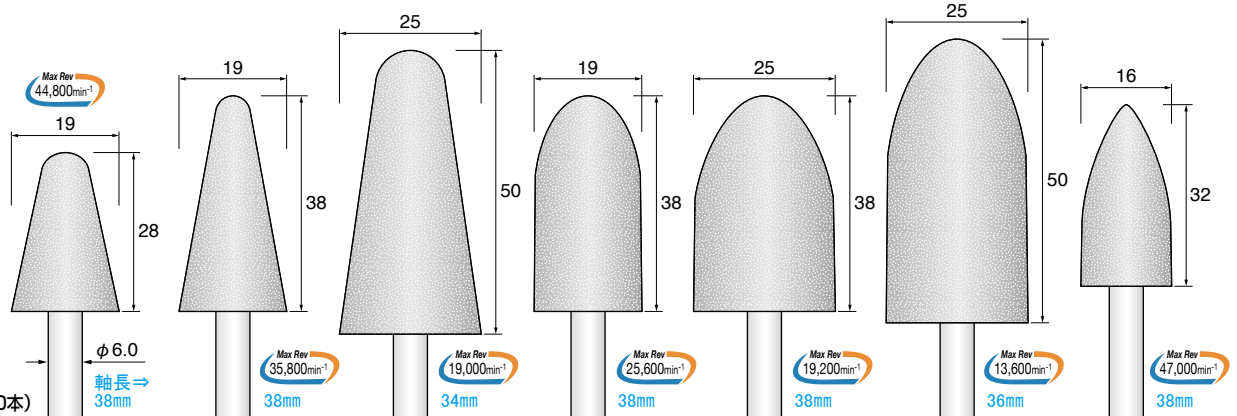

* 販売最小単位 (50本)

WA(茶褐色)	SB1118 #60	SB1119 #60	SB1120 #60	SB1121 #60	SB1122 #60	SB1123 #60	SB1124 #60
WA(ホワイト)	SB1218 #46	SB1219 #46	SB1220 #46	SB1221 #46	SB1222 #46	SB1223 #46	SB1224 #46
A(グレー)	SB1318 #36	SB1319 #36	SB1320 #36	SB1321 #36	SB1322 #36	SB1323 #36	SB1324 #36
PA(ピンク)	SB1418 #60	SB1419 #60	SB1420 #60	SB1421 #60	SB1422 #60	SB1423 #60	SB1424 #60
GC(グリーン)	SB1518 #80	SB1519 #80	SB1520 #80	SB1521 #80	SB1522 #80	SB1523 #80	SB1524 #80
A(ブラック)	—	SB1619 #36	SB1620 #36	SB1621 #36	SB1622 #36	SB1623 #36	—

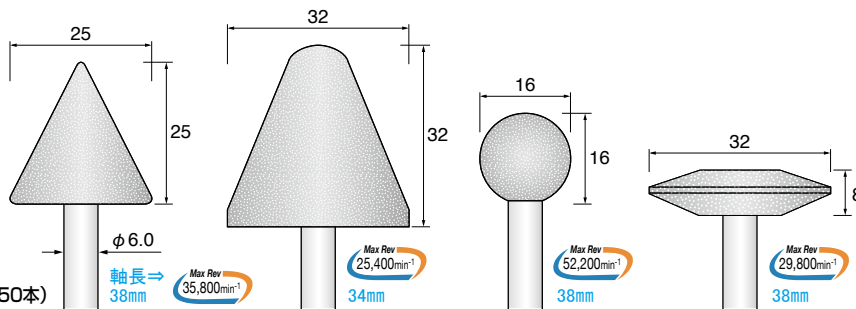

* 販売最小単位 (50本)

WA(茶褐色)	SB1125 #60	SB1126 #60	SB1127 #60	SB1128 #60
WA(ホワイト)	SB1225 #46	SB1226 #46	SB1227 #46	SB1228 #46
A(グレー)	SB1325 #60	SB1326 #36	SB1327 #36	SB1328 #60
PA(ピンク)	SB1425 #60	SB1426 #60	SB1427 #60	SB1428 #60
GC(グリーン)	SB1525 #80	SB1526 #80	SB1527 #80	SB1528 #80
A(ブラック)	—	SB1626 #36	—	—



● A(グレー) 砥石の装着イメージ



● WA(茶褐色) 砥石の装着イメージ

シャंकアダプター Shank Adapters ● 深穴加工に最適!

- 現在使用している工具の軸径を、コレットチャック等を交換しないで簡単に交換出来る、軸径変換用アダプターと、軸長を延長するためのストレッチアダプターです!
- 通常の工具では届かない深穴の加工でも、簡単に軸長を伸ばす事ができます。 ● 特注で工具を製作するコストや時間を節約・短縮できる便利なアダプターです。
- An adapter for shaft diameter conversion that can easily convert the shaft diameter of the tool currently in use without replacing the collet chuck, etc., and a stretch adapter for extending the shaft length!
- The shaft length can be easily extended even when drilling deep holes that cannot be reached with ordinary tools. ● A convenient adapter that can save and shorten the cost and time of custom-made tools.

